

## General Setup Instructions

- Read entire setup instruction manual prior to unpacking parts and pieces.
- The setup instructions are created specifically for this configuration.
- Setup instructions are laid out sequentially in steps, including exploded views with detailed explanation for assembly.

## Cleaning & Packing

- For Cleaning Metal, Plex, & Laminate Parts: Use a **MILD NON-ABRASIVE** cleanser and soft cloth/paper towel to clean all surfaces.
- Keep exhibit components away from heat and prolonged sun exposure. **Heat and UV exposure will warp and fade components.**
- Retain all provided Packing Materials. All provided packing materials are for ease of repacking & component protection.

## Disassembly

- For loss prevention, tighten all set screws and locks during disassembly.

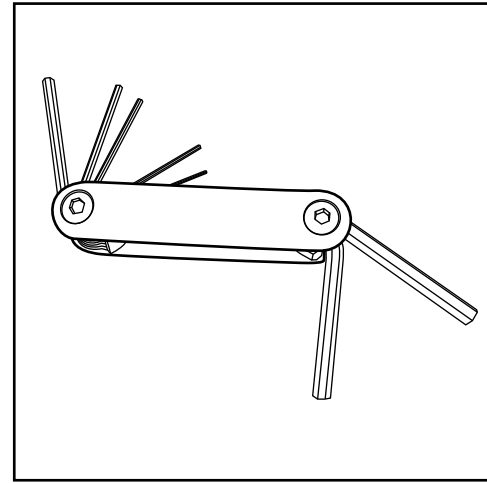

Hex Tool - Essential for Assembly

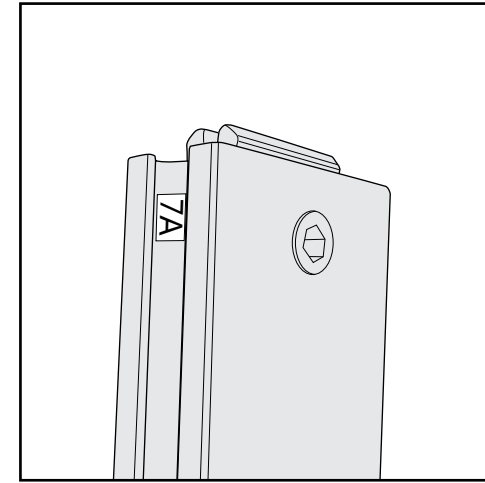

Part Identification - Numbering

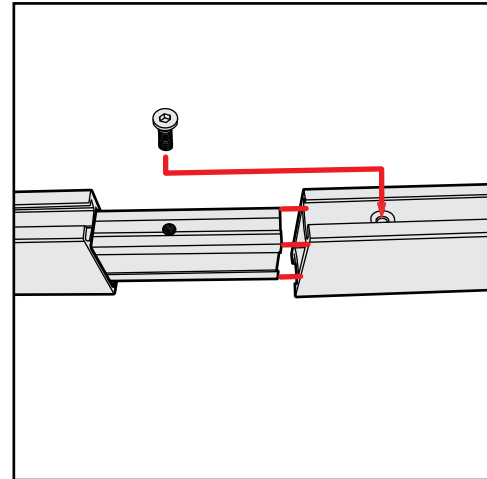

Spline Connection

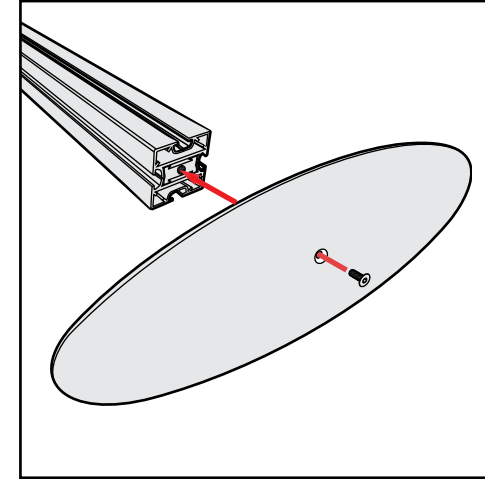

Base Plate & Extrusion Connection

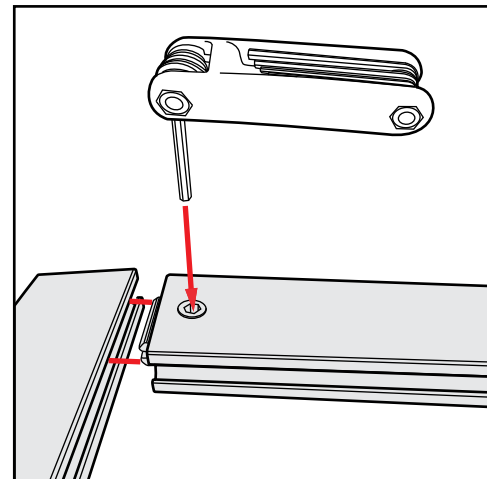

Extrusion & Lock Connection

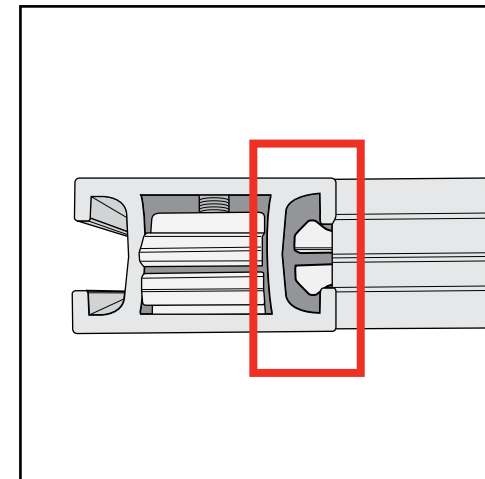

Engaged Lock



**WARNING**



DO NOT USE POWER TOOLS

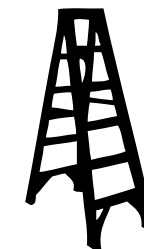

LADDERS OR LIFTS  
MAY BE REQUIRED



ALL CONNECTIONS MUST  
BE TIGHTLY SECURED

## Straight Connection

When assembling frame, first attach all **straight connectors**, then attach **corner connectors**.

- 1) Place extrusions end-to-end.
- 2) Loosen all knobs, then slide **straight connector** across the seam of extrusions.
- 3) Tighten all knobs to secure connection.

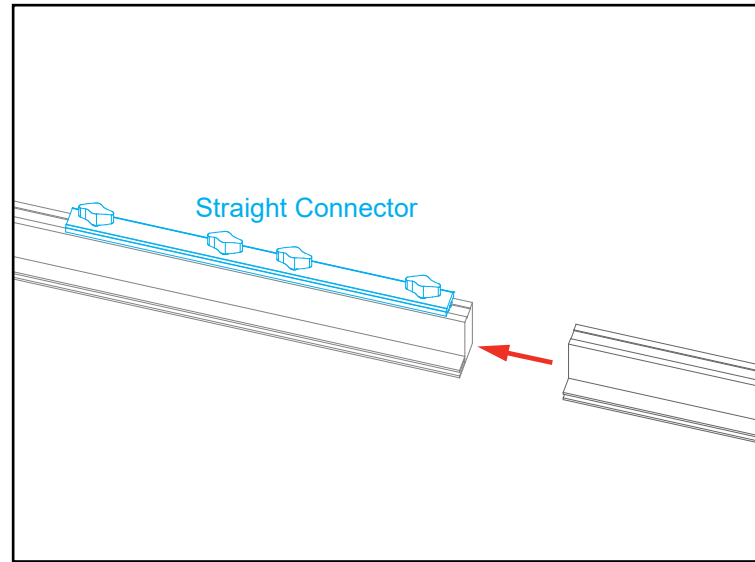

Slide connector across seam of extrusions.  
Tighten all knobs.

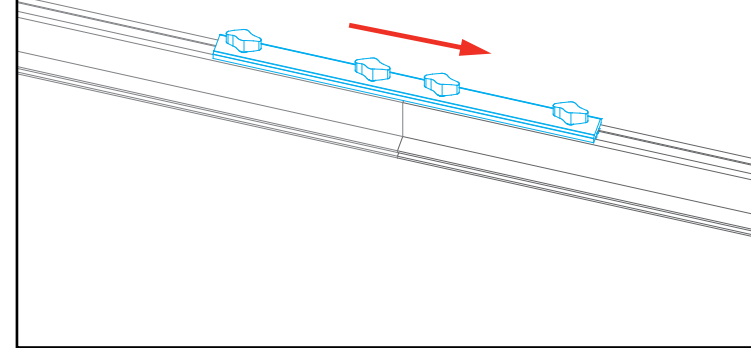

## Disassembly

- 1) Loosen all knobs.
- 2) Slide connectors off of one extrusion.
- 3) Tighten knobs to prevent loss during packing & shipping.

Keep straight connectors in groove of extrusion. Do not remove connectors during disassembly.

All knobs must be tightened securely to ensure a proper connection.

## Corner Connection

- 1) Loosen knobs, then slide vertical extrusions onto **corner connectors** of **lower** horizontal extrusion.
- 2) Slide **corner connectors** of **upper** horizontal extrusion into grooves of vertical extrusions.
- 3) Tighten all knobs to secure connection.

## Disassembly

- 1) Loosen knobs on vertical extrusions.
- 2) Slide the vertical extrusions off of **corner connectors** on lower and upper horizontal extrusions.

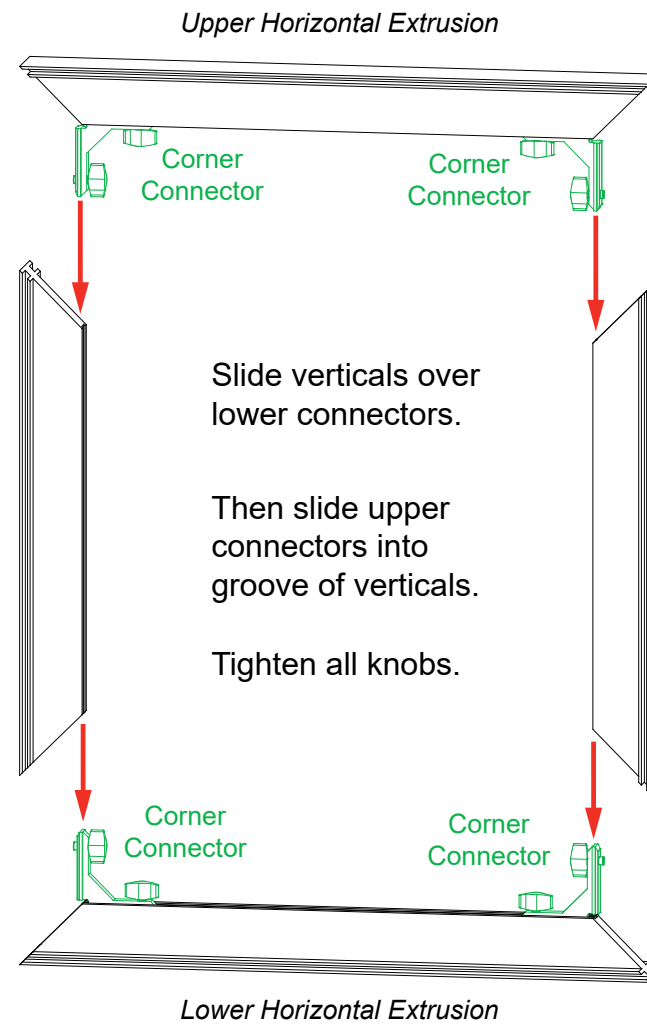

Slide verticals over lower connectors.

Then slide upper connectors into groove of verticals.

Tighten all knobs.



Adjust connectors if necessary to prevent gaps in connection.

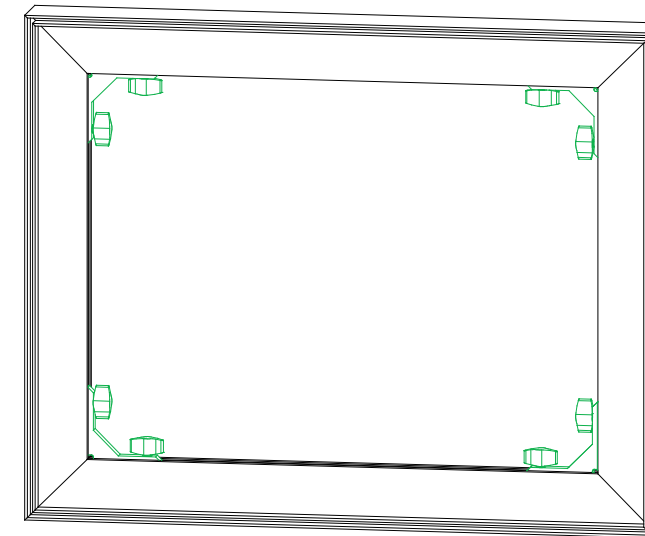

COMPLETED ASSEMBLY

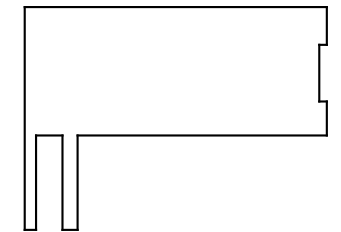

TSP46 Profile

All knobs must be tightened securely to ensure a proper connection.

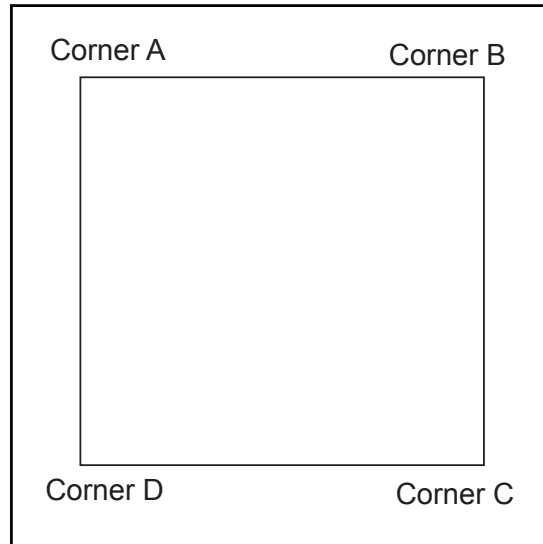

It is important to first insert graphic into each alternate corner then to the sides of the frame. If this is not done, graphic will not fit into the frame correctly.

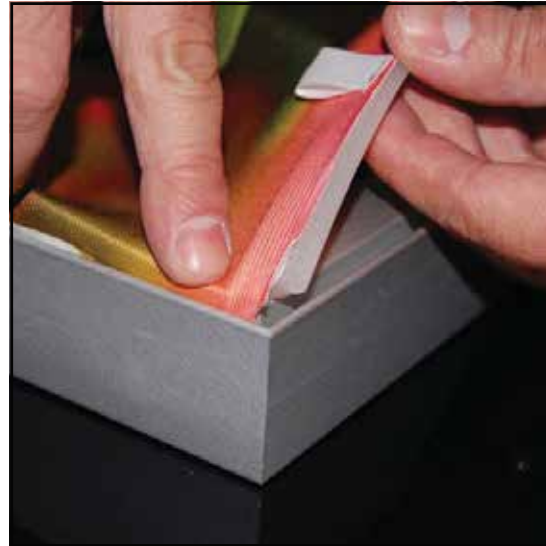

**Step 1**  
Insert corner A. Turn edge of graphic so silicon welt is perpendicular to face of graphic. Insert narrow side of welt with fabric to outside into the channel. Repeat for other side of this corner.



**Step 2**  
Repeat Step 1 for opposite corner C, then insert corner B, followed by corner D, to complete the installation of the corners.



**Step 3**  
Once all corners are inserted, press one silicon edge into channel from corners and work toward the center. Make sure welt is fully inserted into channel. Continue until all sides are done. Smooth out edges of graphic.

### Graphic Removal

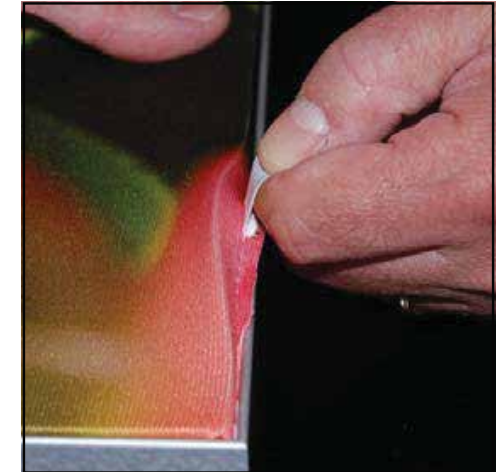

To remove the graphic from the frame, locate the fabric pull tab. Gently pull up on the tab to remove the fabric.

### Top View of Each Level

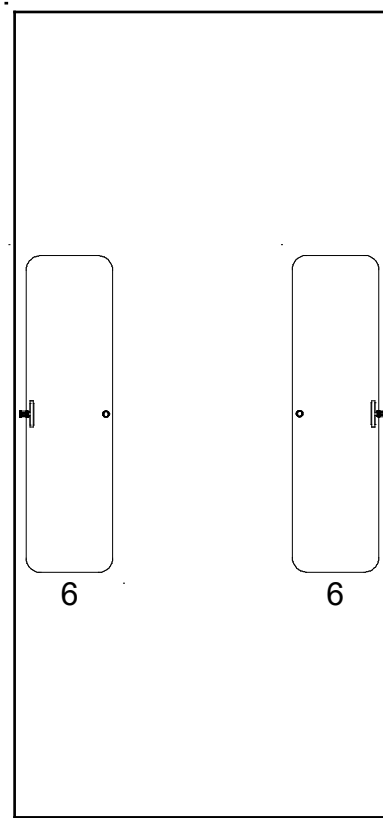

Level 1 (Bottom Level)

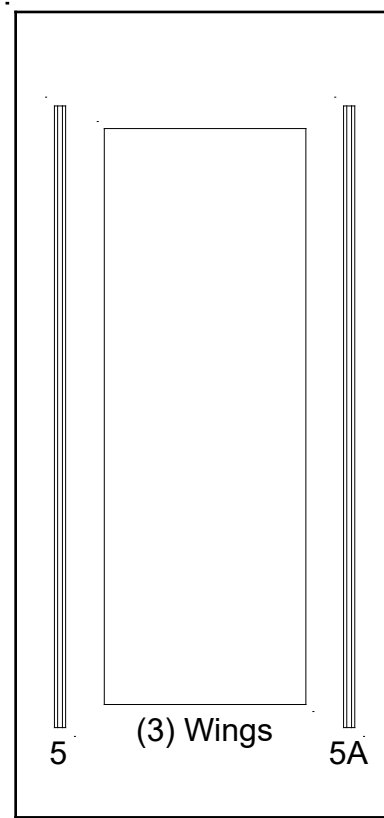

Level 2

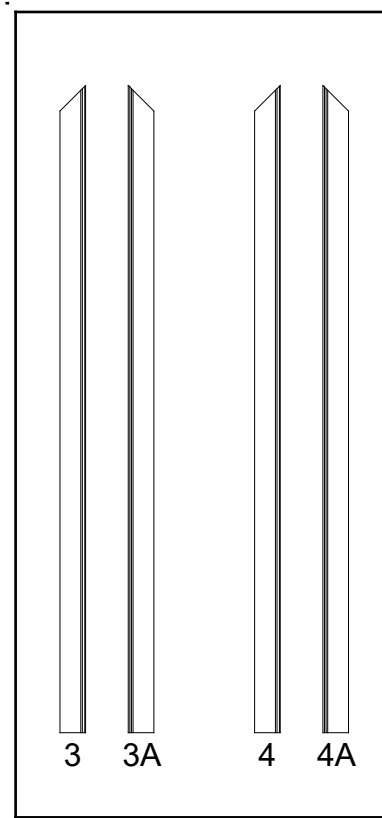

Level 3

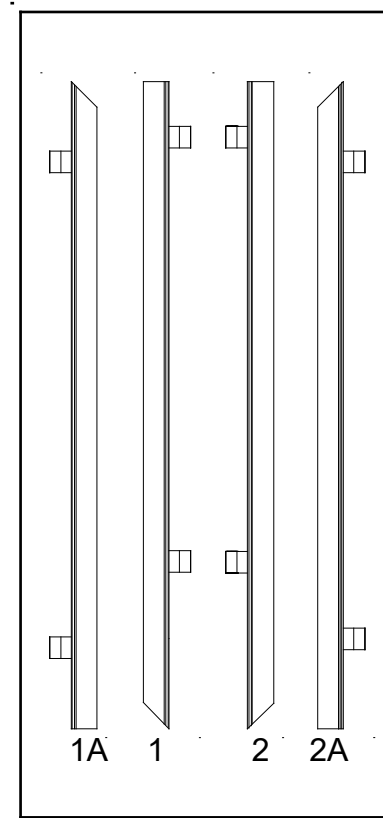

Level 4

Lights

Graphics

Setup Hardware  
w/ Monitor Mount

### Top View of Each Level

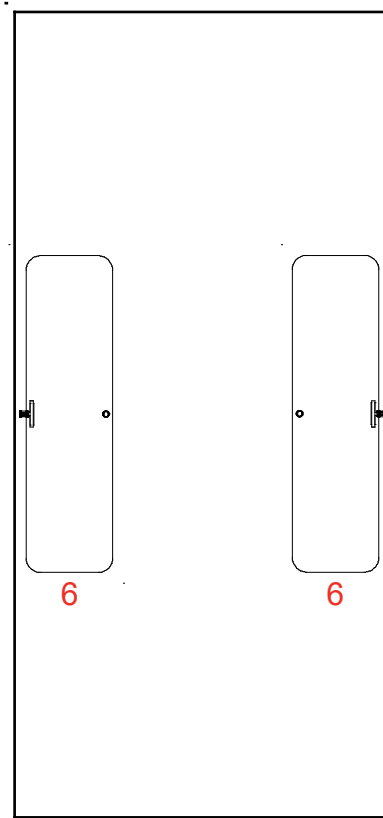

Level 1 (Bottom Level)

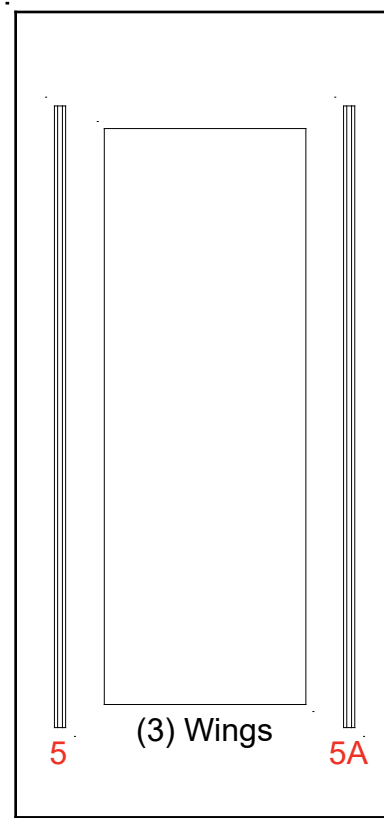

Level 2

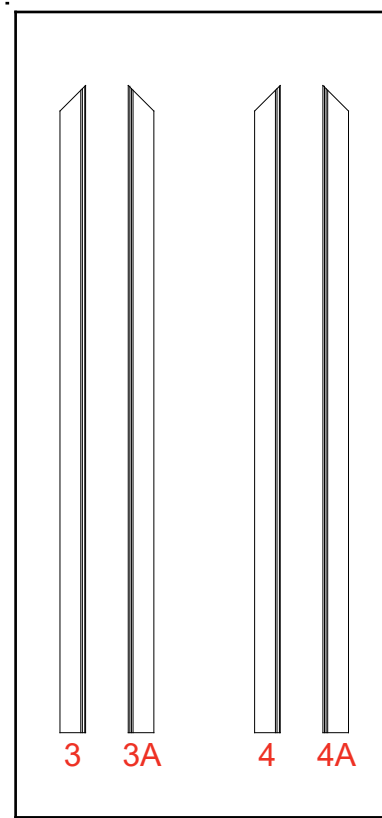

Level 3

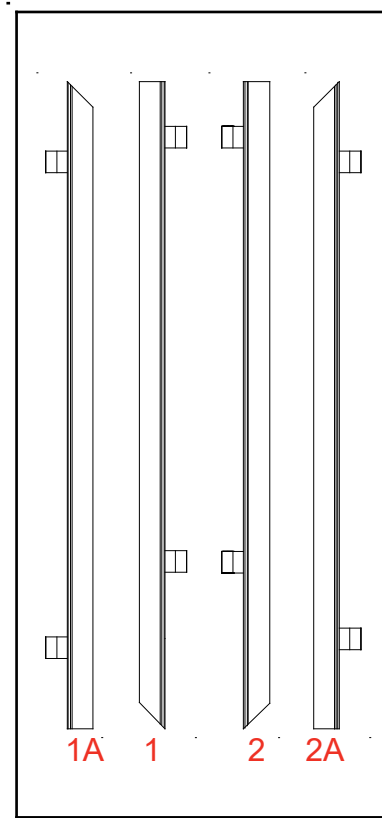

Level 4

Lights

Graphics

Setup Hardware  
w/ Monitor Mount

Item	Qty.	Description
1,1A	1,1	45" TSP46 Vertical Extrusion w/ Clamps
2,2A	1,1	45" TSP46 Vertical Extrusion w/ Clamps
3,3A	1,1	45" TSP46 Horizontal Extrusion
4,4A	1,1	45" TSP46 Horizontal Extrusion
5,5A	1,1	43.2085" Z45 Vertical Extrusion
6	2	Base Plate

Assemble frame flat on ground.

Steps:

Refer to the *Tool-less Frame Assembly* general information page.

- 1) Assemble vertical extrusions [1-1A], [2-2A], [5-5A] & horizontal extrusions [3-3A], [4-4A], using **Tool-less Spline connectors** labeled [X].
- 2) Connect vertical assemblies [1/1A], [2/2A] between horizontal assemblies [3/3A], [4/4A], using **Tool-less Corner Connectors** labeled [A].
- 3) Install Base Plate [6] to bottom corners of frame assembly as shown. See **Base Plate Attachment** detail.
- 4) Lift up frame & connect vertical assembly [5/5A] between horizontals as shown. See **Z45 Connection** detail.

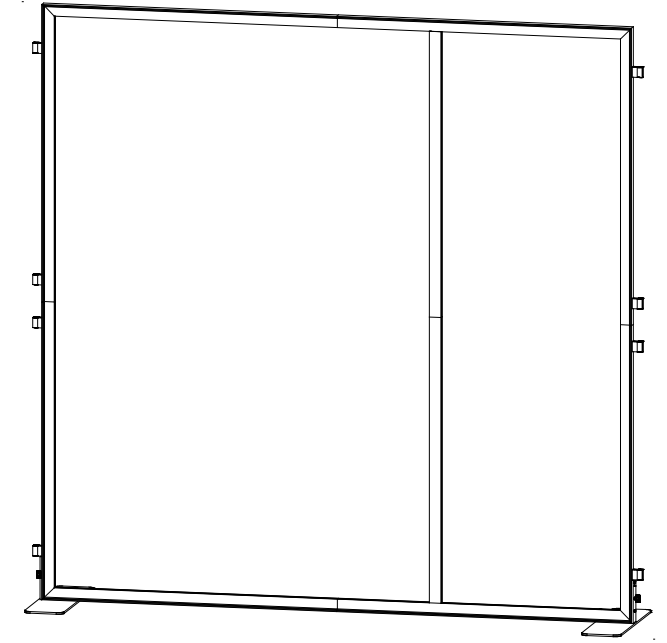

When assembled

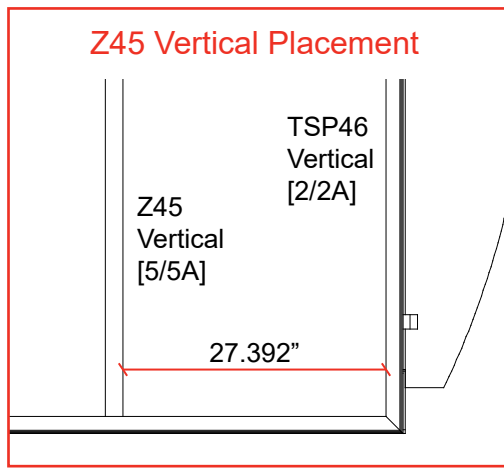
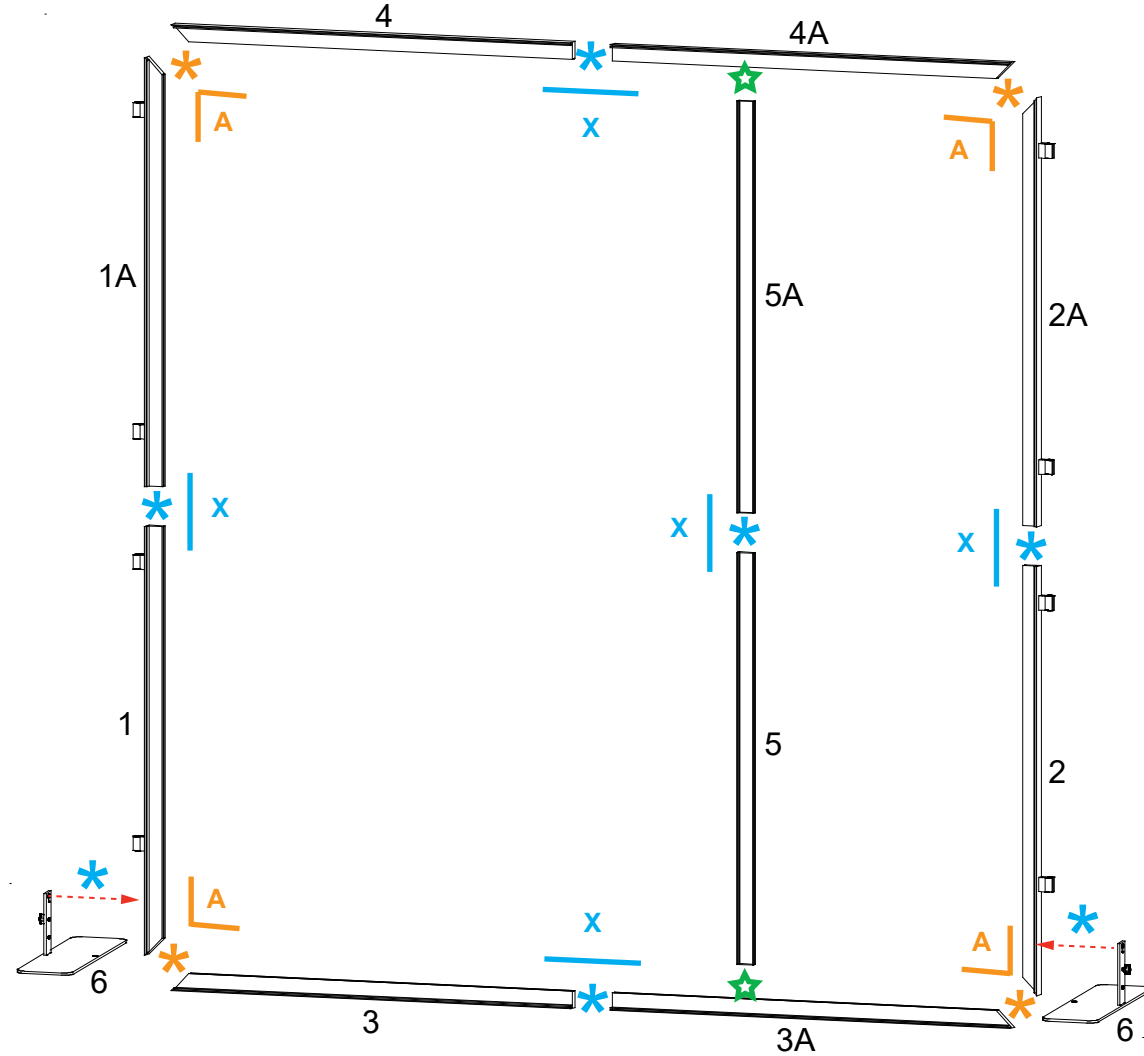
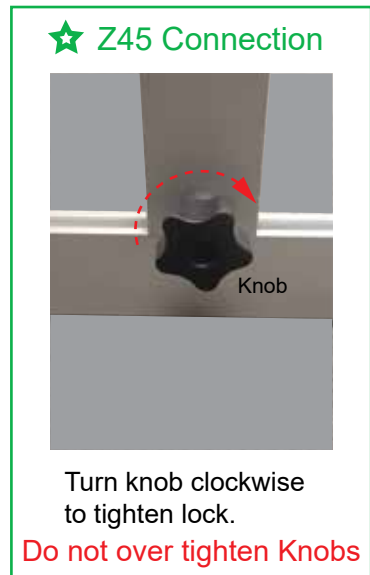

★ Base Plate Attachment

- 1) Place key hole over bolt on panel & slide down.
- 2) Twist knob to secure connection.

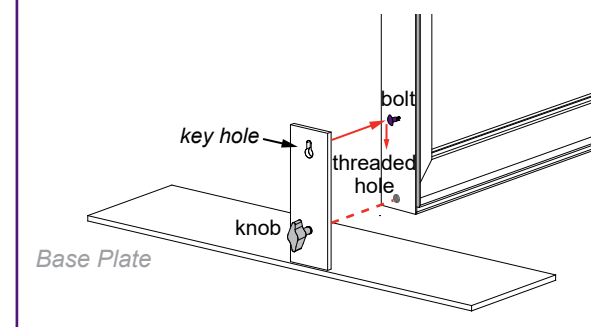

Keep A10 clamps attached to [1] [1A] [2] and [2A], when packing.

Item	Qty.	Description
1,1A	1,1	45" TSP46 Vertical Extrusion w/ Clamps
2,2A	1,1	45" TSP46 Vertical Extrusion w/ Clamps
3,3A	1,1	45" TSP46 Horizontal Extrusion
4,4A	1,1	45" TSP46 Horizontal Extrusion
5,5A	1,1	43.2085" Z45 Vertical Extrusion
6	2	Base Plate

Assemble frame flat on ground.

Steps:

Refer to the *Tool-less Frame Assembly* general information page.

- 1) Assemble vertical extrusions [1-1A], [2-2A], [5-5A] & horizontal extrusions [3-3A], [4-4A], using **Tool-less Spline connectors** labeled [X].
- 2) Connect vertical assemblies [1/1A], [2/2A] between horizontal assemblies [3/3A], [4/4A], using **Tool-less Corner Connectors** labeled [A].
- 3) Install Base Plate [6] to bottom corners of frame assembly as shown. See **Base Plate Attachment** detail.
- 4) Lift up frame & connect vertical assembly [5/5A] between horizontals as shown. See **Z45 Connection** detail.

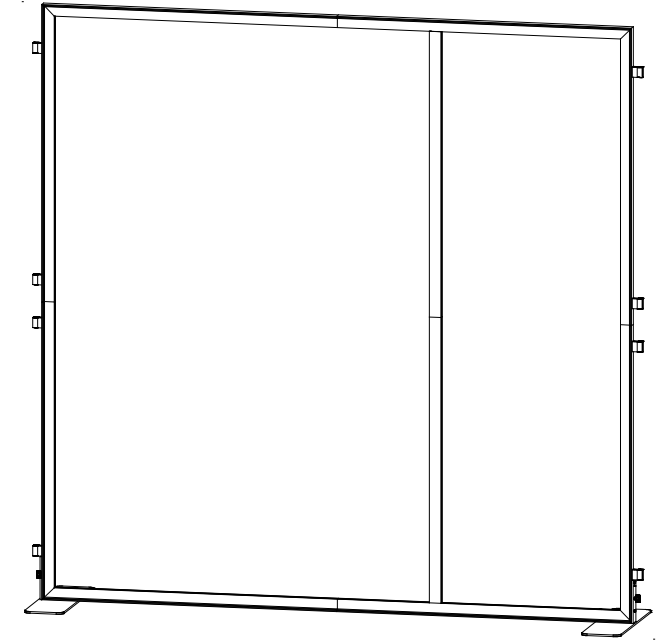

When assembled

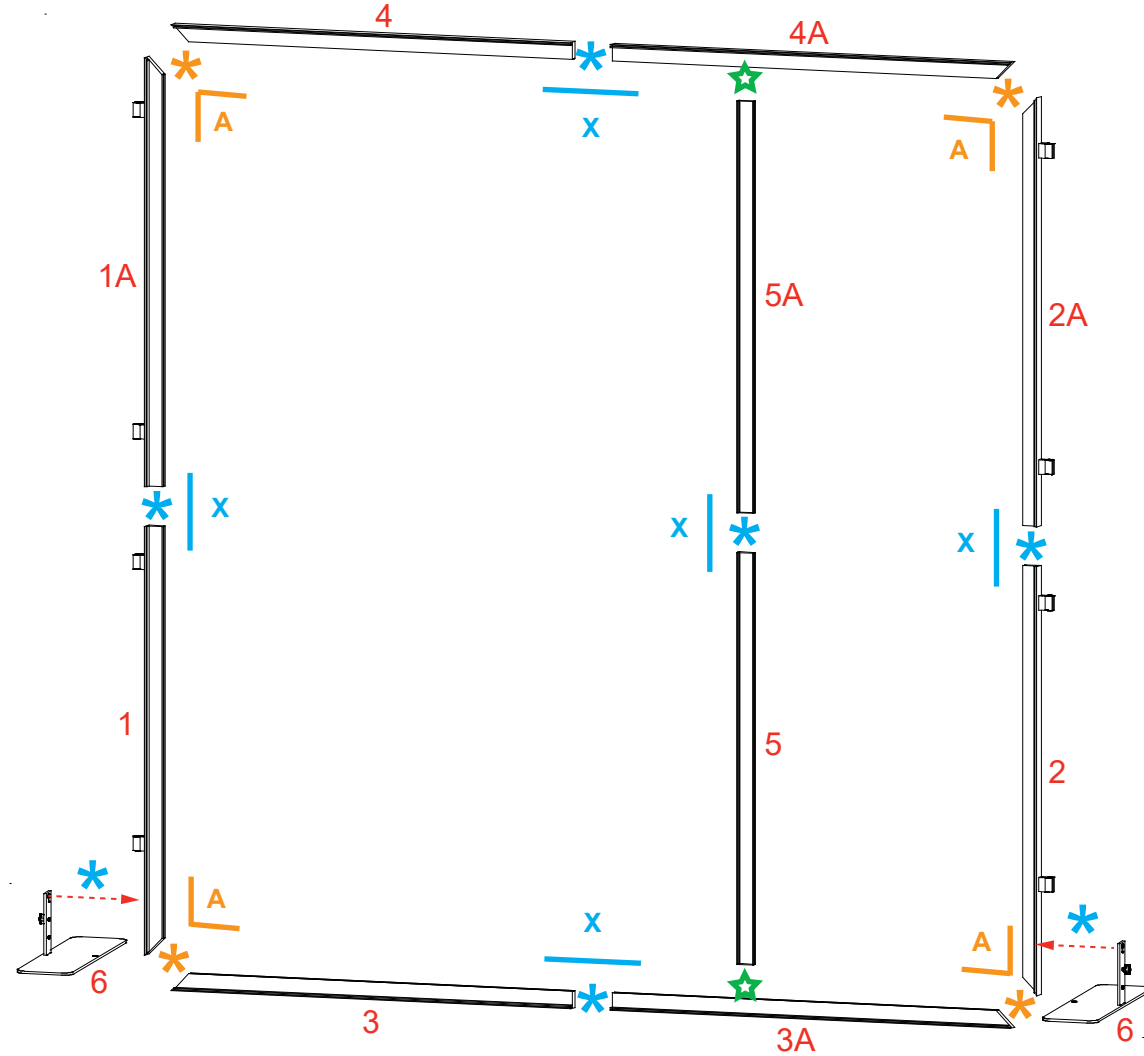
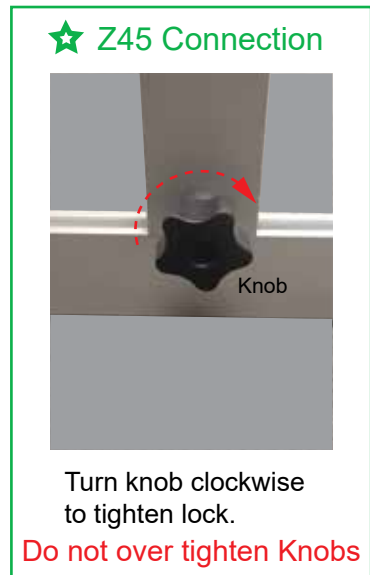

✳ Base Plate Attachment

- 1) Place key hole over bolt on panel & slide down.
- 2) Twist knob to secure connection.

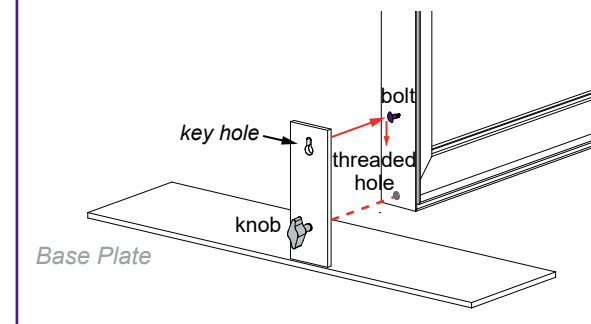

Keep A10 clamps attached to [1] [1A] [2] and [2A], when packing.

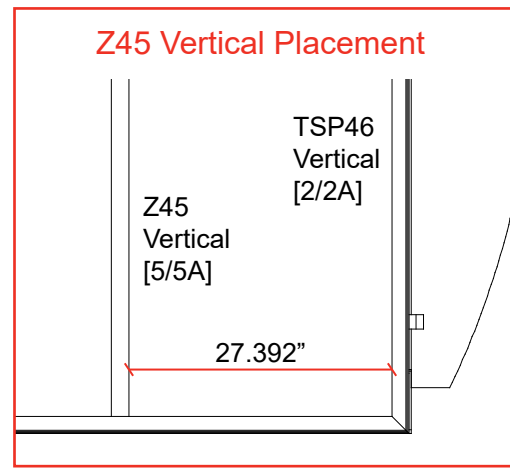



Steps:

Refer to the *SEG Installation general information page*.

- 1) Apply SEG graphics to front of frame assemblies.
- 2) Attach wings to clamps, as shown. See [A10 Clamp Attachment](#) detail.
- 3) Attach monitor mounts to [5A] and [5A]. See [Monitor Mount Attachment](#) detail.
- 4) Attach lights to top of assembled frames. See [Light Connection](#) detail.

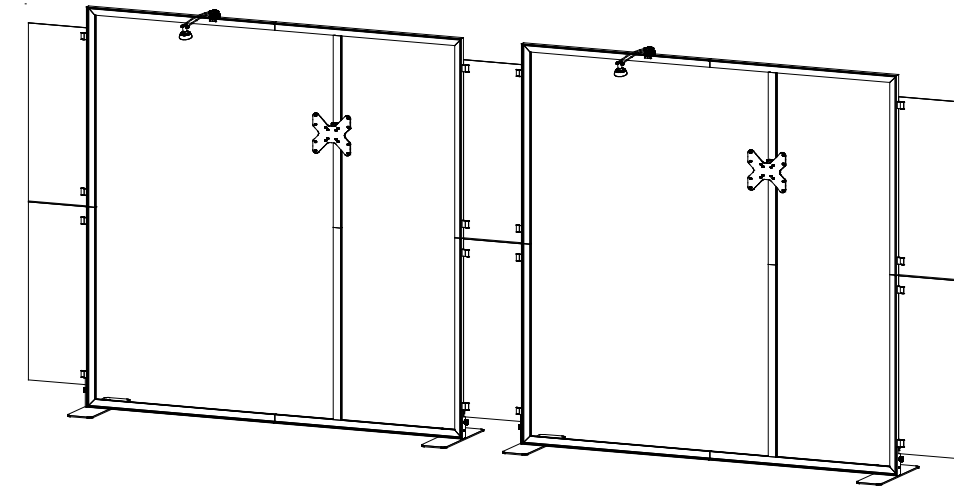

Completed Assembly

**\* Light Connection**

Connect lights to horizontals [4/4A] where desired and tighten in place.

**\* Monitor Mount Attachment**

Attach Monitor Mount back piece to vertical extrusion, using bolts.

Slide monitor mount into back piece.

*Note: Monitor mounts install through SEG graphic.*

**A10 Clamp Attachment**

Screw A10 clamp to Vertical Extrusion.

Tighten knob to secure wing in place.

*Clamps should NOT be removed. Leave attached when packing.*

